

## NAIL FIN INSTALLATION

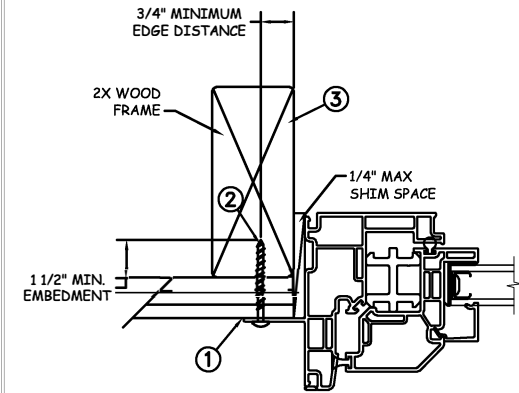
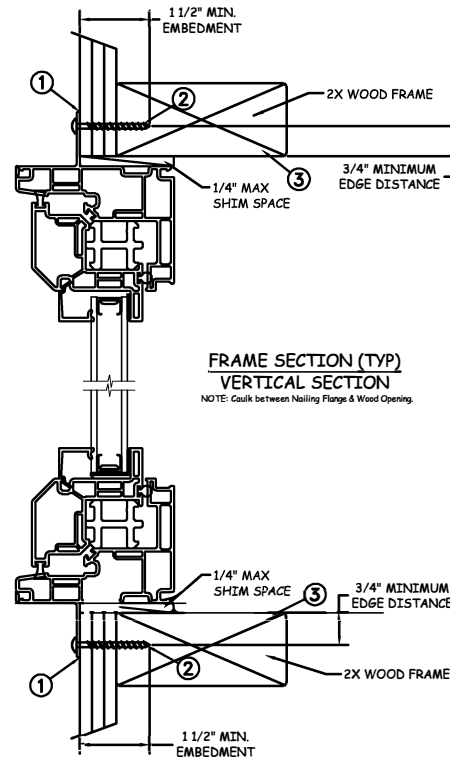
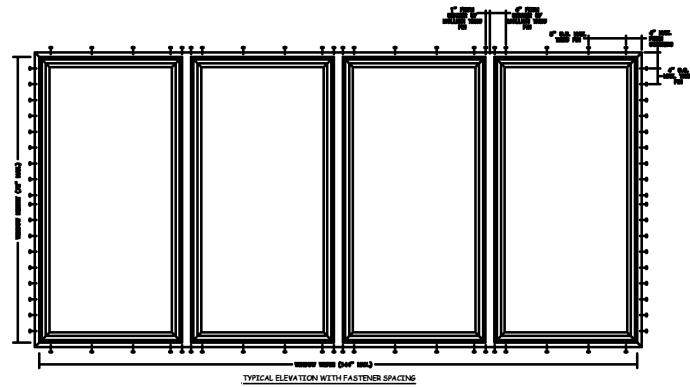

Max Frame	DP RATING	IMPACT
144 x 72	+50/-55	NO

### Installation Notes:

1. Seal flange/frame to substrate.
2. Use #8 PH or greater fastener through the nail fin with sufficient length to penetrate a minimum of 1 1/2" into the wood framing. For 2X wood frame substrate (min. S.G. = 0.42).
3. Host structure (wood buck, masonry, steel) to be designed and anchored to properly transfer all loads to the structure. The host structure is the responsibility of the architect or engineer of record for the project of installation.

### General Notes:

1. The product shown herein is designed, tested and manufactured to comply with the wind load criteria of the adopted International Building Code(IBC), the International Residential Code(IRC), the Florida Building Code(FBC) excluding HVHZ and the industry requirement for the stated conditions.
2. All glazing shall conform to ASTM E1300.
3. At minimum, glazing shall be 5mm annealed - 9.35mm airspace - 5mm annealed insulated glass.
4. Use structural or composite shims where required.

This schedule addresses only the fasteners required to anchor the window to achieve the rated design pressure up to the size limitations noted. It is not intended as a guide to the installation process and does not address the sealing consideration that may arise in different wall conditions. For the complete installation procedure, see the instructions packaged with the window or go to [www.jeld-wen.com](http://www.jeld-wen.com).

### DISCLAIMER:

This drawing and its contents are confidential and are not to be reproduced or copied in whole or in part or used or disclosed to others except as authorized by JELD-WEN Inc.

PROJECT ENGINEER: --	DATE: 12-26-17	<b>JELD-WEN</b> 3737 Lakeport Blvd Klamath Falls, OR. 97601 Phone: (800) 535-3936
DRAWN BY: A. MCMILLAN	SCALE: NTS	
CHECKED BY: J. GOOSSEN	TITLE: Premium Vinyl Stationary Casement OOOO Window	
APPROVED BY: J. GOOSSEN	PART/PROJECT No.: D015171	
IDENTIFIER No. SJW2014-029	PLANT NAME AND LOCATION:	CAD DWG. No.: PremVinylFixedCsmnt Cert
	REV: A	SHEET 1 OF 1